

# TP 200 PTO

All-round wood chipper for mounting onto a tractor.

This is not without reason the most sold model of the TP Wood chippers. Functionality and flexibility have been crucial factors for many buyers. The TP 200 is a disc chipper with hydraulic feed, three knives and three anvils. Simple, flexible and effective for wood chipping of branches and entire trees up to 200 mm in diameter. The wood is carried by two hydraulically powered feed rollers and cut at an angle of 90 degrees. Effect need from 40 to 115 hp.

### Standard on TP 200

- Integrated hydraulics system
- Three knives
- Three anvils in Hardox 400
- Two hydraulically powered feed rollers which ensure a powerful feeding
- Powerful tension spring on moving rollers
- Revolving ejector spout
- Wipers to ensure against accumulation of material at feed rollers and rotor housing
- Changeable casing in rotor housing
- Hydraulic adjustment of the roller speed and thereby the chip size
- Rotor lock for securing the rotor disc when changing knives
- Operating bar start/stop/reversing of the feed rollers
- Danfoss Hydraulic engines
- Comprehensive manual with complete spare parts list
- Tip up funnel
- PTO shaft



TP 100

TP 150

**TP 200**

TP 250

TP 230

TP 270

TP 280

TP 400

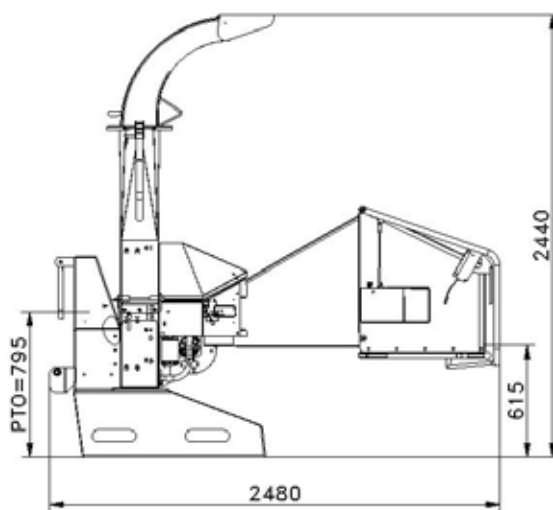
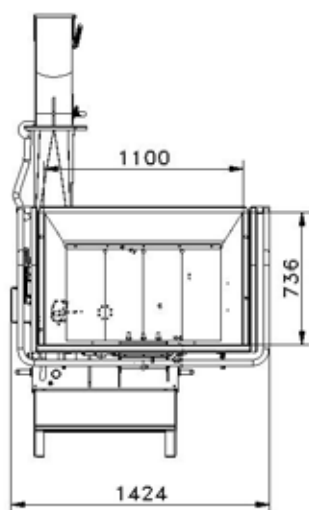

## TECHNICAL DATA

Max wood diameter	200 mm
Max opening	H x W = 210 x 265 mm
Operation	Return/forward/stop of feed rollers through operating bar (yellow)
Chipper principle	Disc
In feed angle	90°
In feed	2 hydraulic feed rollers, spring compressed of 1 spring 8 mm
Feed rollers	Horizontal
Rotordisc - diameter	760 mm with changable end sections of ejector wings
Rotordisc - Weight in kg	168
Number of knives	3 pcs.
Chip lenght	0 - 10 mm (hydraulic ajustable)
Anvil/Counter steel	1 horizontal and 2 vertical
Power required	30-85 kW (40-115 hp)
PTO rpm	540 rpm or 1.000 rpm/min.
PTO shaft	Walterscheid 2400 series with freewheel, length = 560 mm
3-point linkage	Category 1
Chip capacity	6-8 m <sup>3</sup> /hour (Experience numbers by manuel operation)
Weight	700 kg

## EXTRA EQUIPMENT

Speed up gear	Increases the rpm of the tractor from 540 rpm to 1.000 rpm
Stress control system	For protections of the engine of the tractor by monitoring the rpm on the rotor disc
Extended ejector spout	500 mm vertical • 335 mm vertical • 1.000 mm horizontal
Tip-up ejector spout	
Sliverbreakers	Type A or B - are used if extra requirements for chip quality is needed
Light bar	Light bar with complete set of rear lights
Tool kit	Includes tools for daily service and maintenance