

TP 270 PTO

Wood chipper for tractor with hydraulic feeding and with the funnel at a 45 degree angular angle. A forceful and effective wood chipper for chipping wood of up to 270 mm in diameter. The vertical feed rollers and the cutting angle of 45 degrees gives a large capacity and aggressive feeding of even entire trees. TP 270 is available with either manual operation or operation with crane. Effect need from 100 to 200 hp.

TP 270 with manual operation is also equipped with a revolving 3-point suspension so the wood chipper can be turned (hydraulically) behind the tractor in the transport position.

TP 270 is also available in a reversed edition (F) so it can be mounted at the front.

TP 270 is an obvious choice if you want large effectiveness and if coupling to a cart is wanted.

Standard on TP 270

- Integrated hydraulics system
- Three knives
- Three sliver breakers type A
- Two anvils in Hardox 400
- Two hydraulically powered feed rollers which ensure a powerful feeding
- Hydraulic cylinder for backstop of moving rollers
- Revolving ejector spout
- Wipers to ensure against accumulation of material in the rotor housing
- Changeable casing in rotor housing
- Hydraulic adjustment of the roller speed
- Rotor lock for securing the rotor disc when changing knives
- Trailer hitch
- Danfoss Hydraulic engines
- Comprehensive manual with spare parts list



TP 100

TP 150

TP 200

TP 250

TP 230

TP 270

TP 280

TP 400

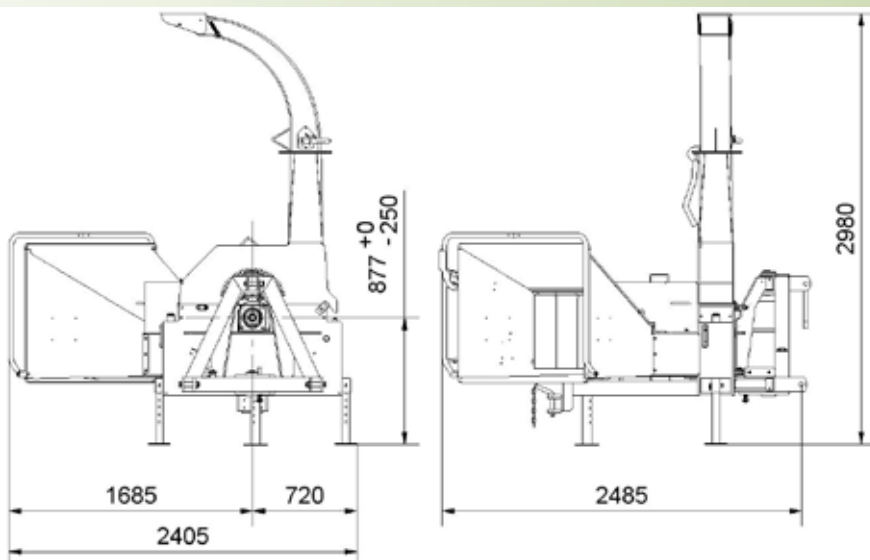

TECHNICAL DATA

Max wood diameter	270 mm
Max opening	H x W = 270 x 290 mm
Operation	Return/forward/stop of feed rollers through operating bar (yellow)
Chipper principle	Disc
In feed angle	45°
Feeding angle	45 ° slanting backwards to driving direction
In feed	2 hydraulic feed rollers
Feed rollers	Vertically
Rotordisc - diameter	960 mm
Rotordisc - Weight in kg	274
Number of knives	3 pcs.
Chip length	12-22 mm
Anvil/Counter steel	1 horizontal and 1 vertical
Sliverbreakers	Type A - Max. opening lxb = 55x30mm
Power required	80-150 kW (100-200 hp)
PTO rpm	540 rpm or 1.000 rpm/min.
PTO shaft	Walterscheid P500 series with freewheel, length = 710 mm
3-point linkage	Category 2
Chip capacity	20-25 m ³ /hour (Experience numbers by manuel operation)
Max allowable pressure on coupling	500 kg
Weight	1385 kg

EXTRA EQUIPMENT

Stress control system	For protection of the engine of the tractor by monitoring the rpm on the rotor disc
Extended ejector spout	500 mm vertical • 1.500 mm horizontal • Extended ejector spout across the tractor 3.700 mm, Height 2230 mm
Tip-up ejector spout	
Sliverbreakers	Type B - are used if extra requirements for chip quality is needed Opening max. 55x17 mm
Light bar	Light bar with complete set of rear lights
Winch	For wood feeding - the winch is towed by the wood chippers hydraulic system
Tool kit	Includes tools for daily service and maintenance